

ECE 342

Electronic Circuits

Lecture 12

Common Source Amplifiers - 4

Jose E. Schutt-Aine
Electrical & Computer Engineering
University of Illinois
jesa@illinois.edu

Example

For the circuit shown, $K = k_n/2 = \mu C_{ox}(W/2L) = 75 \mu\text{A}/\text{V}^2$, $V_T = 1 \text{ V}$, $\lambda = 0$

- (a) Find V_{DQ} , V_{SQ}
- (b) Find the midband gain

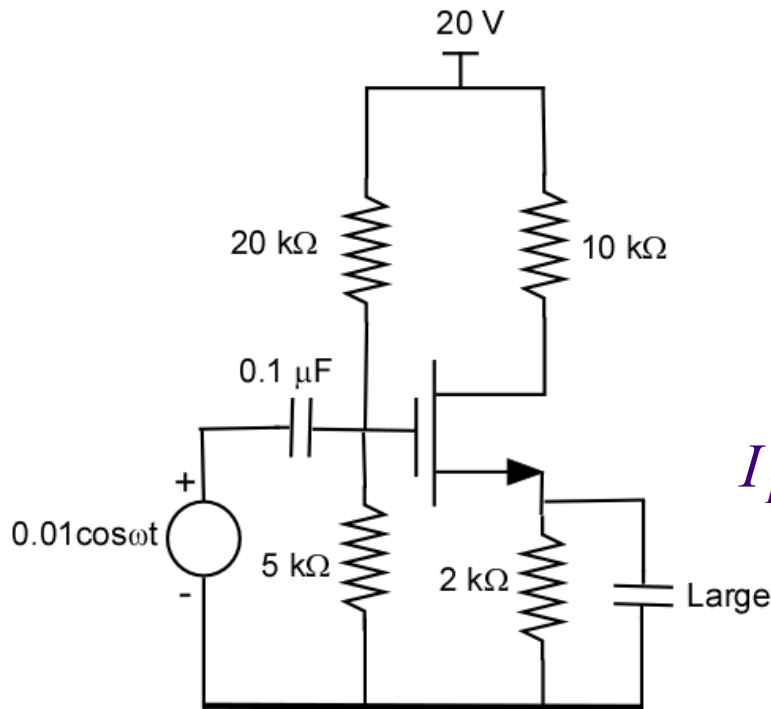

$$V_{GQ} = V_{DD} \frac{R_2}{R_1 + R_2} = \frac{20 \times 5}{25} = 4 \text{ V}$$

$$V_{GSQ} = V_{GQ} - V_{SQ} = 4 - 2I_{DQ}$$

$$I_{DQ} = K [V_{GSQ} - V_T]^2 = 0.075 [4 - 2I_{DQ} - 1]^2$$

$$I_{DQ} = 0.075(9 - 12I_{DQ} + 4I_{DQ}^2)$$

$$4I_{DQ}^2 - 12I_{DQ} + 9 = 13.3I_{DQ} \Rightarrow I_{DQ}^2 - 6.33I_{DQ} + 2.25 = 0$$

Example (Cont')

$$I_{DQ} = 3.167 \pm \frac{\sqrt{6.33^2 - 9}}{2} = 0.378 \text{ mA} \text{ or } 5.953 \text{ mA}$$

reject since voltage drop across R_D will be too large

$$I_{DQ} = 0.378 \text{ mA}$$

$$V_{DQ} = V_{DD} - R_D I_{DQ} = 20 - 10 \times 0.378 = 16.22 \text{ V}$$

$$V_{SQ} = R_S I_{DQ} = 2 \times 0.378 = 0.756 \text{ V}$$

$$V_{DQ} = 16.22 \text{ V}$$

$$V_{SQ} = 0.756 \text{ V}$$

Example (Cont')

$$g_m = \sqrt{2k'_n \frac{W}{L} I_{DQ}} = \sqrt{4 \times 0.075 \times 0.378} = 0.337 \text{ mA/V}$$

$$A_{MB} = -g_m R_D = -0.337 \times 10 = -3.37$$

$$A_{MB} = -3.37$$